

BY	CHK	REVISION RECORD MODIFICATIONS	DATE	REV.
		INITIAL RELEASE	2008.11.03	A.0

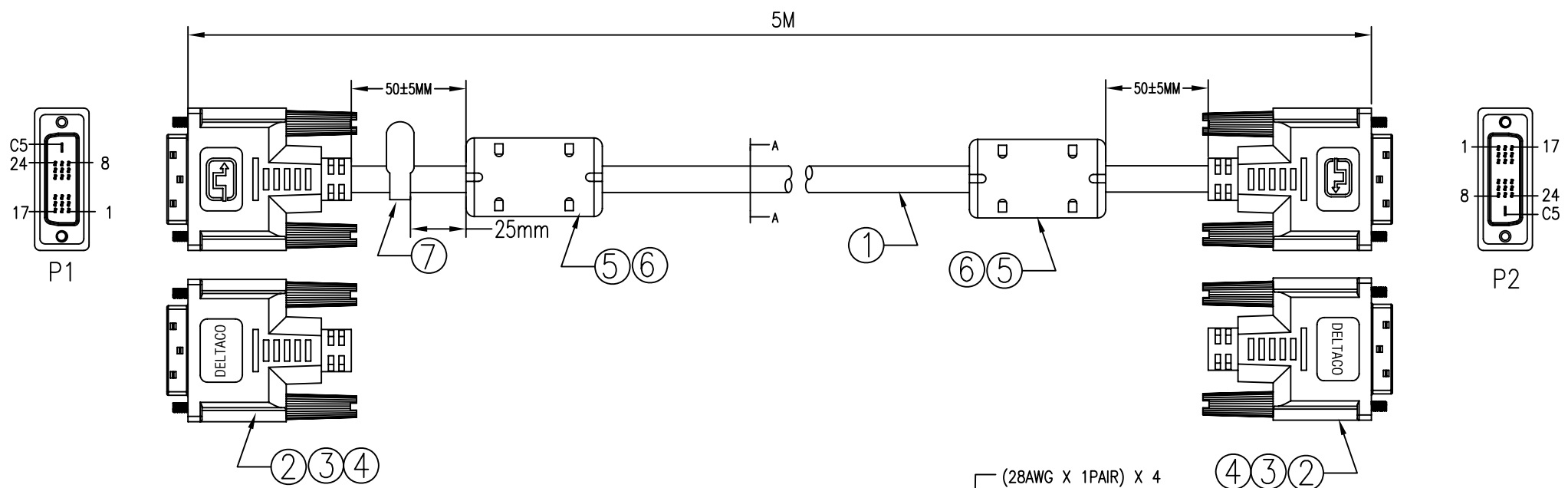

NOTES:

1. ELECTRICAL PROPERTIES:

1.1 100% OPEN AND SHORT TEST

1.2 CONDUCTOR RESISTANCE: 5 OHMS

1.3 INSULATION RESISTANCE: 10 MEGOHMS

1.4 HI-POT: DC300V/0.01S

1.5 100% HDTV, BLUE RAY DVD TEST(1080P:UP TO 7M); (1080I: 10M,15M)

1.6 ALL CABLE PRODUCTION PROCESS ARE CONTROLLED BY ATC TEST DEVICE.

2. ALL MATERIAL BE RoHS COMPLIANT.

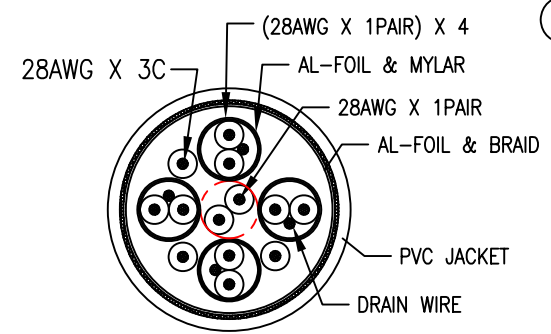
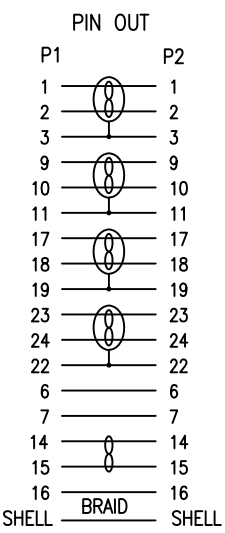

⑦	TAG	1PCS	DELTACO TAG
⑥	CORE MOLD	2PCS	BLACK PVC
⑤	CORE	2PCS	OD*ID*L: 14.3*9.0*28.5mm
④	SCREW	2PCS	#4-40 UNC, HOOD MOLDED: BLACK PVC
③	DVI HOOD	2PCS	BLACK PVC
②	DVI(18+1)M	2PCS	GOLD PLATED SHELL
①	CABLE	1PCS	(28AWG*1P+D+FAM)*4+28AWG*1P+28AWG*3C +AEB OD:7.3mm BLACK PVC JACKET
NO.	PARTS NAME	Q'TY	SPECIFICATION

APPROVED	CHECKED	DRAWN	CUSTOMER:	DESCRIPTION:	
			ITEM NO.	VE011-C	
			DRAW NO.		
			UNIT	mm	
			SCALE	NONE	

DVI(18+1)/M-DVI(18+1)/M